



CAD

CLEAN & ASEPTIC DESIGN

CAD AS-i CONTROL UNIT

MANUAL AND SAFETY INSTRUCTIONS
CODE: YACT-SEND-0AS1-XCU01



 **RATTINOX**
ASEPTIC EQUIPMENT - DESIGN & SUPPLIER

Introduction

This manual concerns the controller: YACT-SEND-0AS1-XCU01

Introduction year: 2024

This user manual contains important information for installing, operating and maintenance of the controller. Read the manual closely and follow the instructions contained in it. For reference, you may keep a copy of the manual.

The pneumatic Valve Controller YACT-SEND-0AS1-XCU01 is not a standalone device. It is meant to be integrated in a larger installation. When installed/connected differently than described in this manual, Rattiinox will not be responsible for any damage or harm created by or to the controller.

The data in this manual is based on the latest information and may be subject to changes.

We can modify our products and any related item such as documentation at any time, without notification.

All the information present in this manual is to be used for installing and operating the controller. All technical and technological information as well as any drawings and technical specifications remain our property and may not be copied or reproduced to any other third party.

Year of release: 2024

INDEX

1. Functions	4
2. General data	4
3. Symbols/Safety regulations	5
4. Installing the controller	6
5. Calibration	8
6. Open/Close	9
7. Swap visual feedback	10
8. Swap electrical feedback	10
9. Error description	11
10. Wiring diagram	12
11. Maintenance	14
12. Cleaning the exterior	14
13. Repair	15
14. Mechanical connections and spare parts	16
15. Standards and CE marking	17
16. Dismounting	18

1. Functions

The YACT-SEND-0AS1-XCU01 is a universal valve controller for automatic control of pneumatic process valves. This means that it can be placed on almost any pneumatic based actuator. Different mounting kits are available to connect the valve controller and actuator.





The controller has the following features:

- Automatic calibration.
- AS-i bus communication.
- Linear and rotating measuring available.
- Contact free measuring.
- Visual feedback on controller through bright LED.
- Internal solenoid for air control.
- Mounting kits available to fit on different actuator brands and sizes.

2. General data

MECHANICAL DATA		
Cap material	:	Stainless steel
Indication ring material	:	PC
Indication ring colour	:	Transparant
Base material	:	Stainless steel
Measuring range	:	Linear 5-25mm
Relative humidity [%]	:	≤ 80
Ambient temperature [°C]	:	-10 ... +50 (non-freezing)
Dimensions [mm]	:	75 x 50 [HxD]
Air flow solenoid [L/min]	:	27
Maximum air pressure [Bar]	:	7
Operating air pressure [Bar]	:	5 - 6
IP rating	:	IP 67

3. Symbols/Safety regulations

	Sign that warns for a possible electric shock.
	General warning sign.
	Refers to additional manuals/datasheets.
	Additional information.
	Advice: We advise you to wear suitable protection clothing, (such as gloves and goggles) when you use cleaning products.

Safety regulations:

- Installation, maintenance and repairs must only be carried out by qualified personnel.
- After maintenance or repair, the unit must be tested before it is put back into service.
- Cleaning should be done in such a way that no water or other fluids can enter any electrical parts of the controller.

The user must ensure that:

- Working conditions are safe.
- The instruction manual is available.

4. Installing the controller

This instruction is specifically for the installation of the unit on a pneumatic actuator and not for the integration into the system.

Installation:

1. Unlock 3 grub screws and disconnect Flange
2. Remove visual indicator from Pneumatic Actuator
3. Read actuator size
4. Select correct adaptor and spring for the actuator size
5. Add one drop of Loctite® on male screw and screw together the adaptor and the pin (Part code CADA0969)
6. Assemble correct spring and assembled pin+adaptor through the flange
7. Place the mounting kit on the actuator keeping stem pulled
8. Screw on the flange keeping stem pulled
9. Release the stem and make sure mounting kit is securely screwed to the actuator
10. Place the control unit on the mounting kit
11. Rotate to the required position
12. Tighten the 3 grub screws
13. Check gently if it is fixed motion-free on the actuator.
No force should be used for this checking
14. Connect the control unit to the actuator using Port A (standard 6mm tube)
15. Connect the air supply to Port P (standard 6mm tube)
16. Install the actuator and YACT-SEN-0AS1-XCU01 on your CAD Valve
17. Plug the electrical connector
18. Run autocalibration function

Normally push-in fittings are installed for 6mm air tubing.
Modifications for other air-fittings are available upon request.

Mounting video tutorial

<https://www.youtube.com/watch?v=QJu6HuVUPGM>



PNEUMATIC CONNECTION

Description	Code
Supply	P
Actuator	A

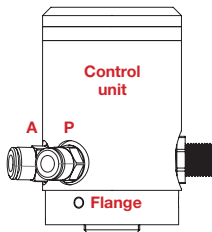

When installing the tubes make sure that:

- The tubing and connections are free of dust and dirt.
- The appropriate tube diameter is used.
- The tubes are long enough.
- The tubes are cut with a “tube cutter”.



Ensure that the YACT-SEND-0AS1-XCU01 and the mounting kit are mounted securely in place to prevent any malfunctions caused by moving the controller.



Air connectors should have parallel thread and O-ring. DO NOT use PTFE tape, as this can cause air leakage and puts tension on the base of the controller.



Avoid magnetic fields around the YACT-SEND-0AS1-XCU01 valve controller.

This may affect the functionality of the controller.



Be careful while connecting and disconnecting electronic connectors.

There is a risk of an electric shock when not handled properly.



While calibrating, the controller will fully open and close the actuator for proper calibration.

Make sure that this cannot cause any harm or damage.



The bright LED can be blinding or harmful when looked straight into.

Do not remove the dome cover.

5. Calibration

After first assembly on an actuator, it is necessary to calibrate the YACT-SEND-0AS1-XCU01. The unit has an auto calibration function which will automatically check the open and close position of the actuator it is assembled on. The auto calibration function can be activated through ASi.

To auto calibrate perform the following steps:

1. Make sure the unit is assembled and connected as described on page 6.
2. Activate bit DO1 of the YACT-SEND-0AS1-XCU01.
3. Wait for 3 seconds. The unit will start to blink green and bit DI0 is activated.
4. Deactivate bit DO1 of the YACT-SEND-0AS1-XCU01.
5. The unit will turn off the leds and activate only bit DO3 to indicate that it is in calibration mode.
6. Wait for the YACT-SEND-0AS1-XCU01 to complete auto calibration.
7. After completion, the YACT-SEND-0AS1-XCU01 is ready for use and will show the current position of the actuator.

6. Open/Close

Functionality of the controller:

This chapter described the way the controller operates. Next to this there is an explanation of the different states and feedbacks the controller gives back.

Air flow:

When the solenoid on the controller is de-activated the airflow towards the controller is blocked. The actuator output is connected to the release of the controller. This state cause air to flow out of the actuator.



The controller will go to this state also when the power is disconnected.

Electrical feedback(s):

The YACT-SEND-0AS1-XCU01 standard mode of operation uses the following rule: The actuator is closed when it is on its lowest position.

The operating mode can be inverted by following the instructions underneath. The ASi bits for the feedback can be seen on page 12.

Visual Feedbacks:

BRIGHT LED FEEDBACK:		
Close	In between	Open
		
RED	OFF	GREEN

The visual feedback can be inverted by following the instructions underneath.

7. Swap visual feedback

The YACT-SEND-0AS1-XCU01 has a possibility to invert the colors of the feedback signals. This means green for close and red for open. Changing the color of the feedback does not affect the electrical feedback signals. Disconnection of the power supply does not affect the switch of the visual feedback.

How to invert the LEDs color:

1. Activate bit DO1 of the YACT-SEND-0AS1-XCU01.
2. After 3 seconds the YACT-SEND-0AS1-XCU01 will blink green and only bit DI0 is activated.
3. After 7 seconds the YACT-SEND-0AS1-XCU01 will blink red and only bit DI1 is activated.
4. Deactivate bit DO1 of the YACT-SEND-0AS1-XCU01.
5. The feedback colors have now been changed and the YACT-SEND-0AS1-XCU01 will continue in normal operation.
6. To switch back the colors, repeat steps 1 to 4.

8. Swap electrical feedback

The YACT-SEND-0AS1-XCU01 has a possibility to invert the electrical feedback signals. Changing the electrical feedback does not affect the visual colors. Disconnection of the power supply does not affect the switch of the electrical feedback.

How to invert the feedback signals:

1. Activate bit DO1 of the YACT-SEND-0AS1-XCU01.
2. After 3 seconds the YACT-SEND-0AS1-XCU01 will blink green and only bit DI0 is activated.
3. After 7 seconds the YACT-SEND-0AS1-XCU01 will blink red and only bit DI1 is activated.
4. After 11 seconds the YACT-SEND-0AS1-XCU01 will alternately blink between red and green. Only bit DI2 is activated.
5. Deactivate bit DO1 of the YACT-SEND-0AS1-XCU01.
6. The feedback colors have now been changed and the YACT-SEND-0AS1-XCU01 will continue in normal operation.
7. To switch back the feedback signals, repeat steps 1 to 5.

9. Error description

Error messaging of the YACT-SEND-0AS1-XCU01 will be indicated by a flashing blue LED. The quantity of blinks indicates the error code mentioned in the table below.

Before trying the solutions mentioned below, please ensure that the unit is mounted securely onto the actuator (this includes the mounting kit). The unit needs to complete its calibration on the actuator it is placed on for proper operation.

LED blinking	Description	Possible cause	Solution
1 time	No calibration in the controller	The controller has not been calibrated before	Calibrate the controller
2 time	Controller lost position	No air flow	Check air connections Check for pressure on the air inlet
		Long magnetic interference	Remove nearby magnets when possible. Re-calibrate if the magnets cannot be removed
		Controller moved on the actuator	Reposition the controller and secure its position with the screws
3 time	Controller did not reach its designated position	Controller has been placed on a different actuator and has not been calibrated	Calibrate the controller
		The actuator cannot fully open or close	 Refer to the manual of the valve-manufacturer on how to safely solve this problem
4 time	Controller did not move after activation of solenoid	No air flow	Check air connections Check for pressure on the air inlet
		Actuator is leaking	Solve leakage
		Valve is blocked	Check valve clearance



While calibrating, the controller will fully open and close the actuator for proper calibration. Make sure that this cannot cause any harm or damage.



Air connectors should have parallel thread and O-ring. DO NOT use PTFE tape, as this can cause air leakage and puts tension on the base of the controller.

10. Wiring diagram

ELECTRICAL DATA			
Power supply	[V]	:	26.5 ... 31.6 DC
Power Consumption	[W]	:	<1,5 or <50mA
Connector		:	M12x1 male
Number of pins		:	4
Open feedback		:	Through AS-i
Open position color	[Dome led]	:	Green*
Close feedback		:	Through AS-i
Close position color	[Dome led]	:	Red*
Fault feedback		:	Through AS-i
Fault color	[Dome led]	:	Blue
Feedback		:	Through AS-i
Solenoid activation	[V]	:	Through AS-i
Pin lay-out			Front view male connector
1. AS-I +		:	Brown
2. Not connected		:	-
3. AS-I -		:	Blue
4. Not connected		:	-



* Colors can be switched

AS-i CONFIGURATION

S-7/A.0.E.**

62-nodes configuration

(1A..31A, 1B..31B)

:

DO 0 = -

DO 1 = Remote calibration

DO 2 = Solenoid 1

DO 3 = -

Normal operation:

DI 0 = Open feedback

DI 1 = Close feedback

DI 2 = Fault feedback

DI 3 = Unit in calibration mode

During calibration

(DO1 activated):

DI 0 = Activate calibration

DI 1 = Switch visual feedback

DI 2 = Switch electrical feedback

DI 3 = -

** Other AS-i configuration are available upon request

11. Maintenance

We point out that you should take care of the equipment according to common technical rules. In case of inappropriate operation or handling by unqualified personnel the guarantee of the manufacturer will not be valid.

Some parts of the controller should be checked on a regular basis. The interval between the checks depends on the surroundings of the controller but should not exceed a year time.

The check includes, but is not limited to, the following part:

- Air connection(s).

Maintenance should be performed by trained and qualified personnel.

12. Cleaning the exterior



Before applying cleaning liquids make sure that they do not damage the equipment.



In case the equipment is contaminated with acids or alkaline cleaner, we recommend rinsing with clean water within 30 minutes. Particular attention must be given to any opening(s) in order to prevent crack formation.



Be careful using liquids on the controller. If liquid gets inside the connector and/or controller it may cause a short circuit or an electric shock.

13. Repair

The valve controller will function without maintenance and trouble if it is appropriately used. In the event of failure, you have the possibility of exchanging parts by your own personnel or to exchange the entire valve controller. The malfunctioning valve controller can be sent to the following address for repair or inspection.

RATTIINOX S.r.l.

Via Pietro Mascagni 10/12

22066 Mariano Comense (CO) Italy

14. Mechanical connections and spare parts

Install the correct needle and the correct spring on sensor shaft according to the following drawing.

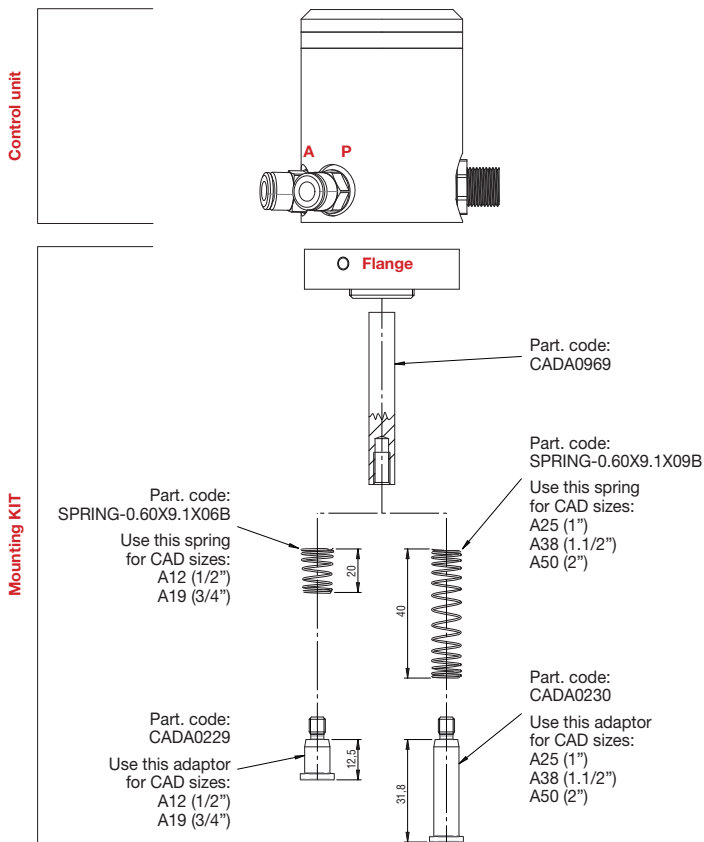

PORT 2: CONNECTION TO ACTUATOR

PORT 1: AIR SUPPLY LINLET

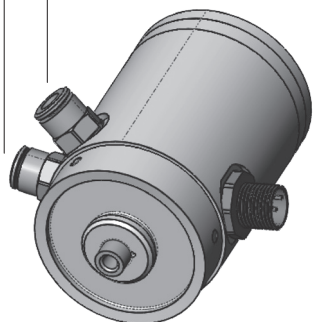

APPLY A DROP
OF LOCTITE 270
OR SIMILAR
BEFORE
SCREWING
THE ADAPTOR

15. Standards and CE marking

This product complies with the following European Community Directives:

2014/30/EU

2014/35/EU

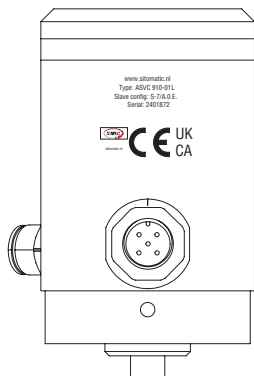

16. Dismounting

1. Depressurize system
2. Remove air supply pipe from connection P
3. Remove piping between AS-i Unit and pneumatic actuator
4. Unlock 3 grub screws
5. Remove Control Unit
6. Unscrew and remove flange, keeping stem pulled

<https://www.youtube.com/watch?v=ZYIzjpSZv1w>



RATTIINOX S.r.l.

Via Pietro Mascagni 10/12 I-22066 Mariano Comense (CO)

T. +39.031.3551263

info@rattiinox.com www.rattiinox.com