

TECHNICAL INFORMATION _ CAT. N. YU## SOCL SOCL A3812

COAXIAL SHUT OFF 90 VALVE 38 ON PIPE + SIP VALVE 12

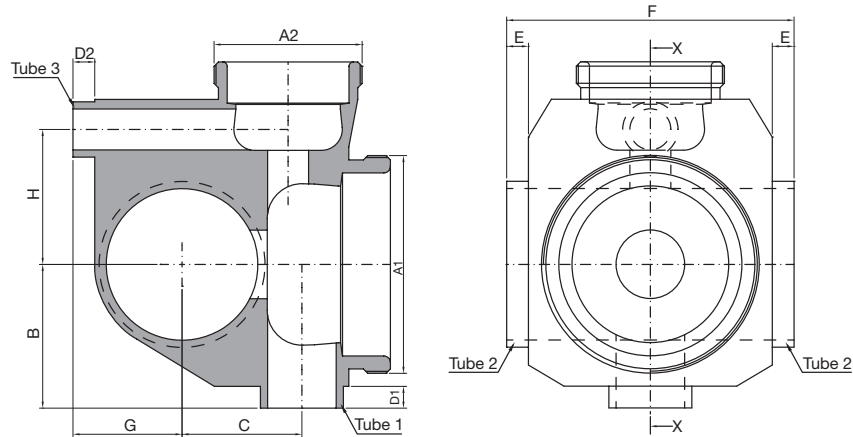

Clean and Aseptic Valves of CAD Product Line have simple and safe design, with their full drainability, without asymptotic seal and dead leg, are offering fast cleanability and sterilization practices. They are designed to fulfill stringent demands of CIP-SIP and Production Cycles on Aseptic Processing.

YU## - SOCL - SOCL - Coaxial Shut Off on Pipe Valves + SIP Valve for SAFE areas designed to feed or take off fluids or gases from the process piping with Zero dead leg. The satellite valve may be used for CIP-SIP process of the Valve on Pipe body and their downstream pipeline. Body shape with flush flow seal on pipe and their internal design offer a very reliable component for Aseptic Processing Application. Standard version are short butt weld ends but, on demand, may be delivered for orbital welding or with Tri-Clamp connections.

CODE	A 1	A 2	B mm (inch)	C mm (inch)	D1 mm (inch)	D2 mm (inch)	E mm (inch)	F mm (inch)	G mm (inch)	H mm (inch)	TUBE 1* mm (inch)	TUBE 2* mm (inch)	TUBE 3* mm (inch)
YU38-SOCL-SOCL-A3812	M80x1,5	M34x1	60,00 (2,36)	37,50 (1,48)	21,00 (0,83)	5,00 (0,20)	21,00 (0,83)	120,00 (4,72)	25,00 (0,98)	44,00 (1,73)	38,10x1,65 (1,50x0,065)	38,10x1,65 (1,50x0,065)	12,70x1,65 (0,50x0,065)
YU50-SOCL-SOCL-A3812	M80x1,5	M34x1	60,00 (2,36)	44,00 (1,73)	21,00 (0,83)	5,00 (0,20)	21,00 (0,83)	120,00 (4,72)	31,50 (1,24)	44,00 (1,73)	38,10x1,65 (1,50x0,065)	50,80x1,65 (2,00x0,065)	12,70x1,65 (0,50x0,065)
YU63-SOCL-SOCL-A3812	M80x1,5	M34x1	60,00 (2,36)	50,50 (1,99)	21,00 (0,83)	5,00 (0,20)	21,00 (0,83)	120,00 (4,72)	38,00 (1,50)	44,00 (1,73)	38,10x1,65 (1,50x0,065)	63,50x1,65 (2,50x0,065)	12,70x1,65 (0,50x0,065)
YU76-SOCL-SOCL-A3812	M80x1,5	M34x1	60,00 (2,36)	56,50 (2,22)	21,00 (0,83)	5,00 (0,20)	21,00 (0,83)	120,00 (4,72)	44,00 (1,73)	44,00 (1,73)	38,10x1,65 (1,50x0,065)	76,20x1,65 (3,00x0,065)	12,70x1,65 (0,50x0,065)

(*) US Tube ASTM® A269/270 – ASME BPE

SPECIFICATION:

CAD SIZE	A12	A38					
-----------------	-----	-----	--	--	--	--	--

NET VOLUME⁽¹⁾	ml	2,86	86,89				
---------------------------------	----	------	-------	--	--	--	--

⁽¹⁾ Internal valve cavity only, for each cavity, with diaphragm on site

MATERIAL	1,4435-BN2 - Low Ferrite - Low Sulphur						
-----------------	--	--	--	--	--	--	--

Design Temperature: -80 to 200 °C (-112 to 392 °F)

Application Areas: SAFE

Design Pressure, Valve Body: -1 to 10 bar (-14.5 to 145 psi)

Note: The applied actuator and diaphragm may have different design temperature and/or pressure limits. The weakest component determines the maximum design temperature and pressure limits, when they are assembled.

Surface Roughness: Internal surface (manually polished) Ra ≤ 0.3µm (16µin)
External surface Ra ≤ 0.5µm (20µin)

Surface Treatment: Available also on EP version - Elettropolishing after manual polished

Labeling: Each valve body is labeled for full LOT traceability

Packaging: Valve body is sealed in plastic bags and packaged in a closed box with Operating and Maintenance bulletin, Certificate of Conformity and Materials Certification 3.1

Quality Control: Quality Assurance System guarantees the control and traceability of the product.

Rules Compliances: CAD valve are on going to be classified for PED Directive 2014/68/EU and fulfill ASME BPE Standards

Standard design: Shut Off bodies are available also to 180°, tangential outlet Left or Right

Options: For non-standard CAD Valve body Options, please contact us for further information.

Orders and Information: For additional information or to place a order call your nearest Distributor or visit www.rattiinox.com

Horizontal Assembly

